



Innovo

Condensing high efficiency water heater

IR 12-160/20-160/12-200/20-200/24-245/32-245/
24-285/32-285/32-380



Fully room-sealed condensing high efficiency water heater • Automatic gas/air premix burning system • Delivered with low-maintenance inert anodes • Efficiency **98%** (gross) • Flexible flue option allows installations to be placed almost anywhere • Construction of the heat exchangers limits scaling effect • External on-/off- switch • Voltage-free contact for general fault indication to BMS • Maximum set point of 85°C • Easy access for maintenance and service; all components are accessible through the front cover • Completely insulated, low stand by losses • Suitable for plastic flue material • Suited for natural gas and butane/propane

Features and options

- Fully room-sealed condensing high-efficiency water heater
- Automatic gas/air premix burning system
- Delivered with low-maintenance inert anodes
- Efficiency 98% (gross)
- Flexible flue option allows installations to be placed almost anywhere
- Construction of the heat exchangers limits scaling effect
- External on-/off- switch
- Voltage-free contact for general fault indication to BMS
- Maximum set point of 85°C
- Easy access for maintenance and service; all components are accessible through the front cover
- Completely insulated, low stand by losses
- Suitable for plastic flue material
- Suited for natural gas and butane/propane

Ecodesign specifications

		IR-12-160	IR-20-160	IR-12-200	IR-20-200	IR-24-245	IR-32-245	IR-24-285	IR-32-285	IR-32-380
Noise level inside	dB(A)	41	52	41	52	53	58	53	58	58
Load profile	-	XL	XL	XL	XL	XXL	XXL	XXL	XXL	XXL
Energy efficiency class	-	A	A	A	A	A	A	A	A	A
Efficiency *	%	92	92	94	91	92	92	91	90	90
Daily electricity consumption	kWh	0.175	0.172	0.181	0.182	0.192	0.201	0.207	0.219	0.204
Daily fuel consumption *	kWh	20.526	20.661	19.924	20.853	26.210	26.255	26.414	26.638	26.748
Annual electricity consumption	kWh/year	38	37	40	40	42	44	45	48	45
Annual fuel consumption *	GJ/year	16	16	16	16	21	21	21	21	21
Mixed water 40°C (acc. to V40)	ltr.	272	772	372	1111	599	1976	682	2282	3372
Other load profile	-	-	-	-	XXL	-	-	-	-	3XL
Energy efficiency class	-	-	-	-	A	-	-	-	-	-
Efficiency *	%	-	-	-	90	-	-	-	-	92
Daily electricity consumption	kWh	-	-	-	0.191	-	-	-	-	0.256
Daily fuel consumption *	kWh	-	-	-	26.761	-	-	-	-	50.428
Annual electricity consumption	kWh/year	-	-	-	42	-	-	-	-	92
Annual fuel consumption *	GJ/year	-	-	-	21	-	-	-	-	40
Mixed water 40°C (acc. to V40)	ltr.	-	-	-	382	-	-	-	-	548

Technical specifications

		IR-12-160	IR-20-160	IR-12-200	IR-20-200	IR-24-245	IR-32-245	IR-24-285	IR-32-285	IR-32-380
Gas data natural gas 2H (G20)										
Input (gross value)	kW	12.1	20.0	12.1	20.0	24.4	32.2	24.4	32.2	32.2
Output full load	kW	11.7	19.1	11.9	19.1	23.5	30.7	23.8	31.0	31.3
Gas consumption *	m ³ /h	1.2	1.9	1.2	1.9	2.3	3.1	2.3	3.1	3.1
Nitrogen oxide emission (NOx)	mg/kWh	22	30	22	30	33	37	33	37	37
Flue gas discharge temperature	°C	42	61	42	61	57	65	57	65	65
Gas data 3P (G31)										
Input (gross value)	kW	11.8	19.6	11.8	19.6	23.9	31.5	23.9	31.5	31.5
Output full load	kW	11.4	18.7	11.6	18.7	23.0	30.1	23.3	30.4	30.7
Gas consumption *	m ³ /h	0.4	0.7	0.4	0.7	0.9	1.2	0.9	1.2	1.2
Nitrogen oxide emission (NOx)	mg/kWh	23	30	23	30	33	37	33	37	37
Flue gas discharge temperature	°C	39	56	39	56	55	59	55	59	59
General										
Efficiency (gross value)	%	96	95	98	95	96	95	97	96	97
Empty weight	kg	95	95	106	106	120	120	136	136	155
Maximum weight	kg	255	255	306	306	365	365	420	420	534
Capacity	ltr.	160	160	200	200	245	245	285	285	380
Maximum working pressure	kPa (bar)	800 (8)								
Draw-off capacity **										
T_{cold} = 10°C / T_{set} = 85°C										
Draw-off capacity immediately $\Delta T=44^\circ\text{C}$	ltr.	140	150	250	260	300	300	380	390	510
30 min. $\Delta T=44^\circ\text{C}$	ltr.	250	320	360	430	510	570	590	660	790
60 min. $\Delta T=44^\circ\text{C}$	ltr.	360	510	470	620	740	870	820	960	1100
90 min. $\Delta T=44^\circ\text{C}$	ltr.	480	690	590	810	970	1200	1100	1300	1400
120 min. $\Delta T=44^\circ\text{C}$	ltr.	590	880	710	990	1200	1500	1300	1600	1800
Continuous $\Delta T=44^\circ\text{C}$	ltr./h	230	380	240	380	470	610	470	610	620
Draw-off capacity immediately $\Delta T=50^\circ\text{C}$	ltr.	120	130	220	230	250	260	330	330	440
30 min. $\Delta T=50^\circ\text{C}$	ltr.	210	270	310	380	440	500	510	570	680
60 min. $\Delta T=50^\circ\text{C}$	ltr.	310	440	410	540	640	760	720	840	950
90 min. $\Delta T=50^\circ\text{C}$	ltr.	410	600	510	710	840	1100	920	1200	1300
120 min. $\Delta T=50^\circ\text{C}$	ltr.	510	770	610	870	1100	1300	1200	1400	1500
Continuous $\Delta T=50^\circ\text{C}$	ltr./h	210	330	210	330	410	530	410	540	540
Draw-off capacity immediately $\Delta T=55^\circ\text{C}$	ltr.	100	110	190	200	220	230	290	300	390
30 min. $\Delta T=55^\circ\text{C}$	ltr.	180	240	270	340	390	440	460	520	610
60 min. $\Delta T=55^\circ\text{C}$	ltr.	270	390	370	490	570	690	650	760	860
90 min. $\Delta T=55^\circ\text{C}$	ltr.	370	540	460	640	760	930	830	1000	1100
120 min. $\Delta T=55^\circ\text{C}$	ltr.	460	690	550	790	940	1200	1100	1300	1400
Continuous $\Delta T=55^\circ\text{C}$	ltr./h	190	300	190	300	370	490	380	490	500
Heating Up time $\Delta T=44^\circ\text{C}$	min.	27	17	41	27	25	20	31	24	31
Heating Up time $\Delta T=50^\circ\text{C}$	min.	31	19	47	30	29	22	35	27	36
Heating Up time $\Delta T=55^\circ\text{C}$	min.	34	21	52	33	32	24	39	30	39
Electrical data										
Power consumption (maximum)	W	85	85	85	85	105	105	105	105	105
Power consumption (nominal)	W	25	36	25	36	51	85	51	85	85
Power supply	VAC/Hz	230 (-15+10%)/50 (+/-1Hz)								
IP-classification	-	IP20								
Transport data										
Weight incl. packaging	kg	114	114	122	122	136	136	153	153	172
Width packaging	mm	786								
Height packaging	mm	1462	1462	1694	1694	1694	1694	1894	1894	1894
Depth packaging	mm	946								

* Gas consumption at 15°C and 1013.25 mbar

** Based on natural gas

Dimensions

			IR-12-160 IR-20-160	IR-12-200 IR-20-200	IR-24-245 IR-32-245	IR-24-285 IR-32-285	IR-32-380
A	Height*	mm	1269	1543	1543	1743	1743
D	Width	mm	560	560	610	610	675
E	Depth	mm	780	780	830	830	895
H	Height air supply/flue gas discharge*	mm	1310	1310	1350	1350	1350
Hx	X position air supply/flue gas discharge	mm	145	145	145	145	145
Hy	Y position air supply/flue gas discharge	mm	325	325	350	350	385
K	Height Gas connection*	mm	870	870	910	910	910
M	Height Cold water supply*	mm	175	175	175	175	175
N	Height hot water outlet*	mm	1270	1545	1545	1745	1745
Nx	X position hot water outlet	mm	50	50	50	50	50
Ny	Y position hot water outlet	mm	90	90	90	90	90
P	Height cleaning opening*	mm	155	155	280	280	280
R	Height drain valve*	mm	105	105	105	105	105
S	Height T&P valve connection*	mm	1070	1325	1330	1535	1520
V	Height circulation pipe connection*	mm	605	605	690	690	690
W	Height condensation drainage*	mm	180	180	180	180	180
1	Cold water (external)	-	Rp 3/4	Rp 3/4	Rp 1	Rp 1	Rp 1
2	Hot water (external)	-	Rp 3/4	Rp 3/4	Rp 1	Rp 1	Rp 1
3	Gas control (external)	mm	15	15	15	15	15
4	Drain valve (internal)	-	Rp 3/4	Rp 3/4	Rp 3/4	Rp 3/4	Rp 3/4
5	T&P valve (internal)	-	Rp 3/4	Rp 3/4	Rp 1	Rp 1	Rp 1
6	Cleaning and inspection opening	mm	95x70	95x70	95x70	95x70	95x70
7	Condensation drainage (external)	mm	Ø 40	Ø 40	Ø 40	Ø 40	Ø 40
8	Circulation (internal)	-	Rp 3/4	Rp 3/4	Rp 3/4	Rp 3/4	Rp 3/4
9	Flue connection	mm	80/125	80/125	80/125	80/125	80/125

* This is the minimal height. When the adjustable legs under the water heater are fully extended, the height is 20 mm higher.

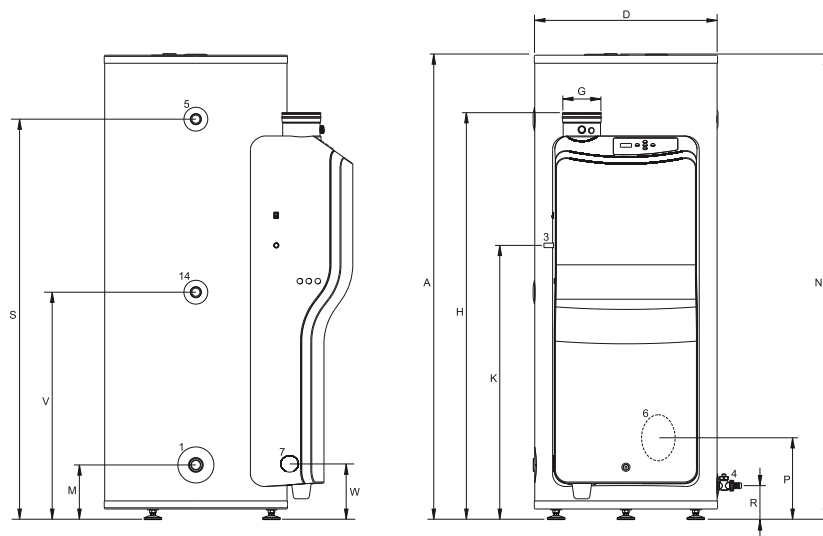
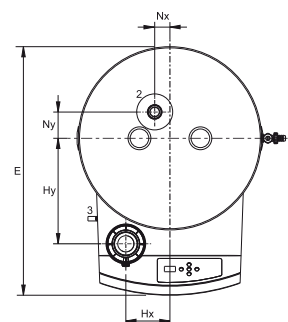

IMD-1201a R1



Installation drawing

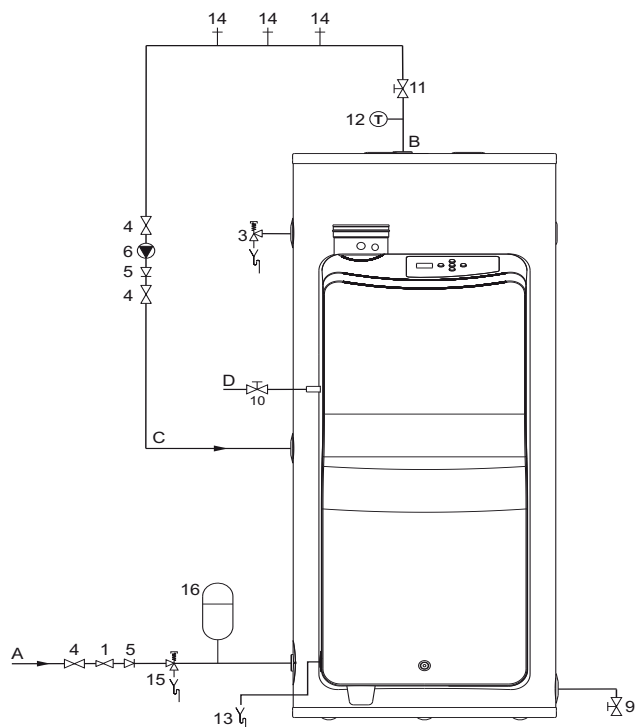

- 1 Pressure reducing valve
- 2 Inlet combination valve
- 3 T&P valve
- 4 Stop valve
- 5 Non-return valve
- 6 Circulation pump
- 9 Drain valve
- 10 Gas valve
- 11 Service valve
- 12 Temperature Gauge
- 13 Condense drain
- 14 Hot water tap

- A Cold water supply
- B Hot water outlet
- C Circulation pipe
- D Gas supply

In the instruction manual you will find all the necessary information regarding connection, installation and maintenance of the product; including information on the electrical connections.

Information regarding the recycling or disposal of the product can also be found in the manual. This manual is delivered with the appliance and can also be found on our website; www.aosmith.co.uk

Accessories	
Conversion kit to LPG	0312313(S)
Conversion kit to NAT	0312312(S)
Gas valve 15mm compression fitting	0312305(S)
Safety inlet group	0302706(S)
T&P valve 3/4" 150psi	0076527004(S)
T&P valve 1" 150psi	0099383005 (S)

Installation options

	IR-12-160 IR-20-160 IR 12-200 IR-20-200	IR-24-245 IR-32-245 IR-24-285 IR-32-285 IR-32-380
Concentric		
Diameter (mm)	80/125	80/125
Max. length (m)	40	40
Max. 45/90° bends	8	8
Parallel (standard diameter)		
Diameter (mm)	80	80
Max. length (m)	50	75
Lequivalent/bend 90° (m)	3.9	3.9
Lequivalent/bend 45° (m)	1.1	1.1

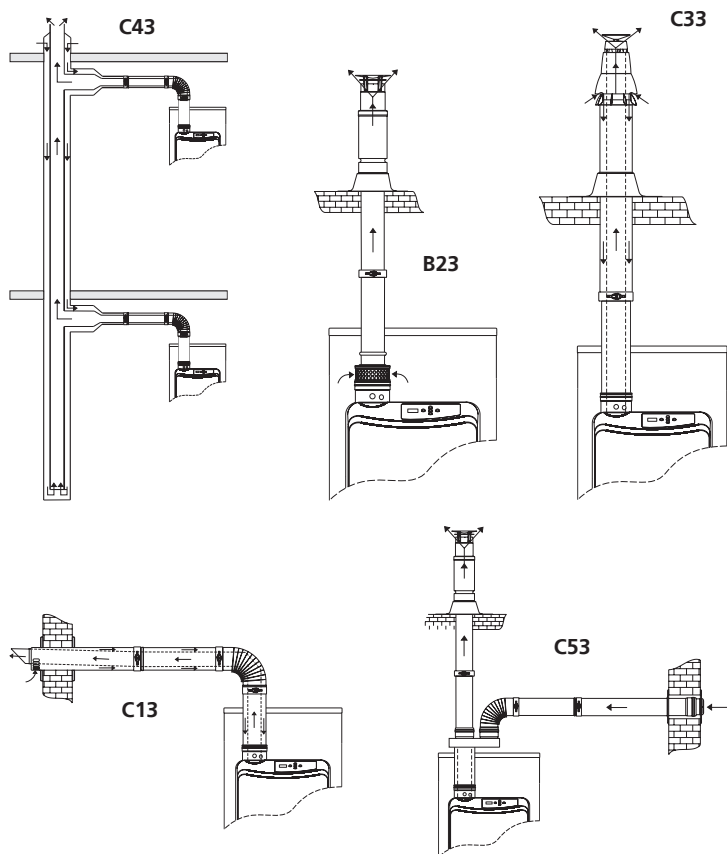

Further information on the flue gas discharge materials can be found in the Installation Manual.

Concentric system (80/125mm)		
	PP	Alu
Roof flue terminal set (Roof flue terminal, 1000mm tube, mounting flange Ø140mm)	0310755	0305042
Roof flue terminal	0310753	0304983
Wall flue terminal set (Wall flue terminal, 500mm tube, bend 90°)	0310759	0302515
Wall flue terminal	0310757	0302516
Wall flue terminal plate	0310761	-
Tube concentric	L = 250 mm	0310740
	L = 500 mm	0310741
	L = 1000 mm	0310742
	L = 1500 mm	-
	L = 2000 mm	0310743
	Telescopic (280-395 mm)*	0310744
Bend concentric	Bend = 45°	0310734
	Bend = 90°	0310735

Parallel system (80/80mm)		
	PP	Alu
Adaptor PP/Alu 80/125 --> 2x 80 mm	0312209	0312209
Roof flue terminal set (Roof flue terminal, 1000mm tube, mounting flange)	0310712	-
Roof flue terminal (incl. transition piece)	0310708	0305041
Wall flue terminal set (Wall flue terminal, 500mm tube, bend 90°)	0310730	-
Wall flue terminal (incl. transition piece)	0310728	0305016
Tube	L = 250 mm	0310718
	L = 500 mm	0310719
	L = 1000 mm	0310720
	L = 1500 mm	-
	L = 2000 mm	0310721
	Telescopic (240-360 mm)*	0310722
Bend	Bend = 45°	0310701
	Bend = 90°	0310702
Bend 90° with support	0310703	-
Support for bend 90° with support	0310690	-

B23 system		
Air inlet basket 80/125		0305030

* Use this part to connect the air inlet and flue gas outlet to the water heater.

Data subject to change UK Adveco/0520/Innoovo/08
Terms and conditions apply, please refer to our website