

BFC Cyclone

Condensing Glass-Lined Water Heater

BFC - 28/30/50/60/80/100/120



Fully room-sealed condensing high-efficiency water heater **97%** (gross) • Automatic gas/air premix burning system including burner modulation • Delivered with low-maintenance inert anodes • Efficiency 97% (gross) • NOx emission ≤ 30 ppm (dry – air free) – NOx class 5 • Whisper quiet operation (<45 dB(A) at 2m distance from duct) • Varying water temperature setting from 40°C to 80°C with use of week timer • Flexible flue options (maximum length 100m) allow installations to be placed almost anywhere • Easy fault diagnosis and computer controlled digital week timer • Programmable for legionella purge cycle • Voltage-free contact for general fault indication to BMS • BFC Cyclone 80-120 are delivered on steel base for convenient transport and installation

Features and options

- Fully room-sealed condensing high-efficiency water heater **97%** (gross)
- Automatic gas/air premix burning system including burner modulation
- Delivered with low-maintenance inert anodes
- Efficiency 97% (gross)
- NOx emission ≤ 30 ppm (dry – air free) – NOx class 5
- Whisper quiet operation (<45 dB(A) at 2m distance from duct)
- Varying water temperature setting from 40°C to 80°C with use of week timer
- Flexible flue options (maximum length 100m) allow installations to be placed almost anywhere
- Easy fault diagnosis and computer controlled digital week timer
- Programmable for legionella purge cycle
- Voltage-free contact for general fault indication to BMS
- BFC Cyclone 80-120 are delivered on steel base for convenient transport and installation

Technical specifications

		BFC 28	BFC 30	BFC 50	BFC 60	BFC 80	BFC 100	BFC 120
Gas data natural gas 2H (G20)								
Input*	kW	32.2	33.3	52.2	63.3	86.6	105.5	128.8
Output	kW	31.0	32.7	50.3	60.4	84.2	100.7	121.8
Inlet pressure	mbar	20	20	20	20	20	20	20
Gas consumption **	m ³ /h	3.1	3.2	5.0	6.0	8.3	10.1	12.3
Flue gas discharge	°C	45	50	60	65	50	55	60
Gas data propane 3P (G31)								
Input*	kW	31.5	32.6	51.1	62.0	84.8	103.3	126.1
Output	kW	31.0	32.7	50.3	60.4	84.2	100.7	121.8
Inlet pressure	mbar	37/50	37/50	37/50	37/50	37/50	37/50	37/50
Gas consumption **	kg/h	2.3	2.3	3.7	4.4	6.1	7.4	9.0
Flue gas discharge	°C	45	50	60	65	50	55	60
General								
Nox	ppm	30	29	29	27	31	30	29
Noise level	dB(A)	< 45	< 45	< 45	< 45	< 45	< 45	< 45
Efficiency (gross)	%	96	98	96	95	97	95	95
Weight empty	kg	177	214	214	214	480	480	480
Maximum weight	kg	394	582	582	582	960	960	960
Storage capacity	l	217	368	368	368	480	480	480
Max. temperature setting	°C	80	80	80	80	80	80	80
Maximum working pressure	kPa (bar)	800 (8)						
Draw-off capacity ***								
$T_{set} = T_{max} / T_{cold} = 10^{\circ}C$								
30 min. $\Delta T=44^{\circ}C$	l	430	550	730	840	1100	1300	1500
60 min. $\Delta T=44^{\circ}C$	l	730	870	1300	1500	1900	2300	2600
90 min. $\Delta T=44^{\circ}C$	l	1100	1200	1800	2100	2800	3200	3800
120 min. $\Delta T=44^{\circ}C$	l	1400	1500	2300	2700	3600	4200	5000
Continuous $\Delta T=44^{\circ}C$	l/h	610	640	990	1200	1700	2000	2400
Heating-up time $\Delta T=44^{\circ}C$	min.	21	35	22	19	17	15	12
30 min. $\Delta T=50^{\circ}C$	l	360	450	620	720	910	1100	1300
60 min. $\Delta T=50^{\circ}C$	l	630	730	1100	1300	1700	2000	2300
90 min. $\Delta T=50^{\circ}C$	l	900	1100	1500	1800	2400	2800	3400
120 min. $\Delta T=50^{\circ}C$	l	1200	1300	2000	2300	3100	3700	4400
Continuous $\Delta T=50^{\circ}C$	l/h	540	570	870	1100	1500	1800	2100
Heating-up time $\Delta T=50^{\circ}C$	min.	24	39	26	21	20	17	14
30 min. $\Delta T=55^{\circ}C$	l	320	390	540	630	800	920	1100
60 min. $\Delta T=55^{\circ}C$	l	560	650	940	1100	1500	1700	2100
90 min. $\Delta T=55^{\circ}C$	l	800	900	1400	1600	2200	2500	3000
120 min. $\Delta T=55^{\circ}C$	l	1100	1200	1800	2100	2800	3300	4000
Continuous $\Delta T=55^{\circ}C$	l/h	490	520	790	950	1400	1600	2000
Heating-up time $\Delta T=55^{\circ}C$	min.	27	43	28	23	22	18	15
Elektrical data								
Power consumption	W	45	45	75	115	95	145	240
Power supply	VAC/Hz	230 (-15% +10% VAC)/50 (\pm 1Hz)						
Shipping data								
Weight incl. packaging	kg	196	235	235	235	501	501	501
Width packaging	mm	790	790	790	790	920	920	920
Height packaging	mm	1550	2080	2080	2080	2060	2060	2060
Depth packaging	mm	950	950	950	950	1020	1020	1020

* Gas data on gross value

** Gas consumption at 15°C and 1013.25 mbar

*** Based on natural gas

Dimensions

BFC 28-60

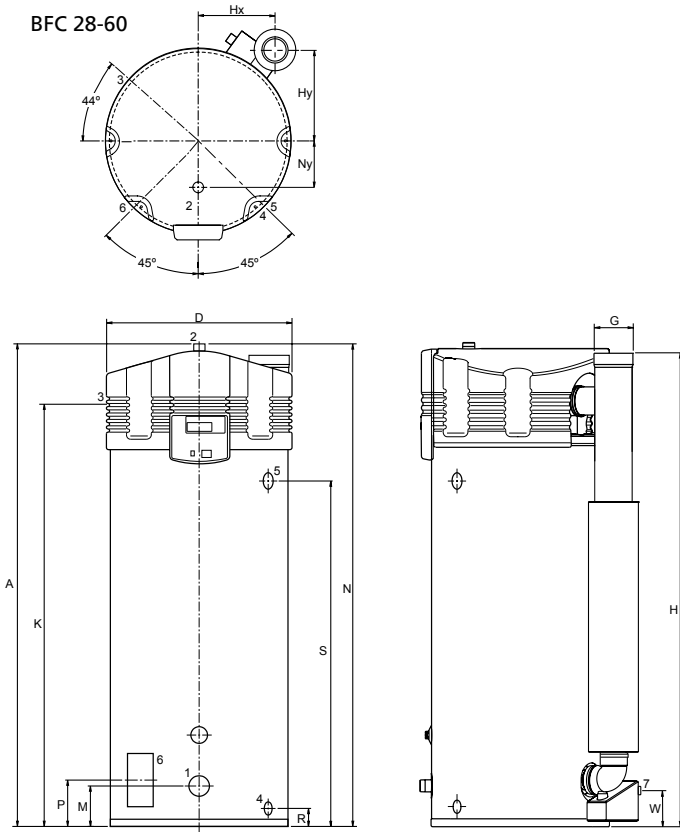

	BFC 28	BFC 30	BFC 50	BFC 60	BFC 80	BFC 100	BFC 120
A	1390	1910	1910	1910	2060	2060	2060
C	-	-	-	-	530	530	530
D	705	705	705	705	850	850	850
E	-	-	-	-	1000	1000	1000
F	-	-	-	-	900	900	900
G	100/150	100/150	100/150	100/150	130/200	130/200	130/200
H	1365	1905	1905	1905	1995	1995	1995
Hx	265	265	265	265	310	310	310
Hy	375	375	375	375	440	440	440
K	1285	1815	1815	1815	1855	1855	1855
M	170	160	160	160	225	225	225
N	1390	1910	1910	1910	2060	2060	2060
Ny	205	205	205	205	205	205	205
P	170	175	175	175	290	290	290
R	85	75	75	75	225	225	225
S	900	1410	1410	1410	1425	1425	1425
W	150	150	150	150	240	240	240
1	Cold water (external)				R 1 1/2		
2	Hot water (external)				R 1 1/2		
3	Gas control (external)				R 3/4"		
4	Tank drain valve (internal)				1" (28-60) 3/4" (80-120)		
5	T&P valve (internal)				1" - 11.5 NPT		
6	Cleaning and inspection opening				95x70		
7	Condensation drainage (internal)				Ø 40		

Dimensions in mm.

BFC 80-120

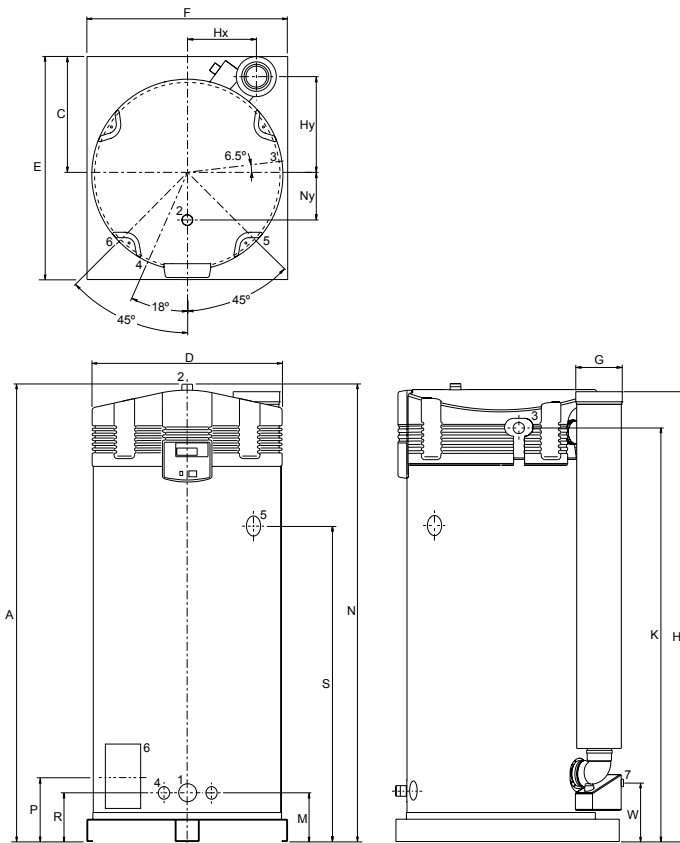

Installation diagrams

Unvented

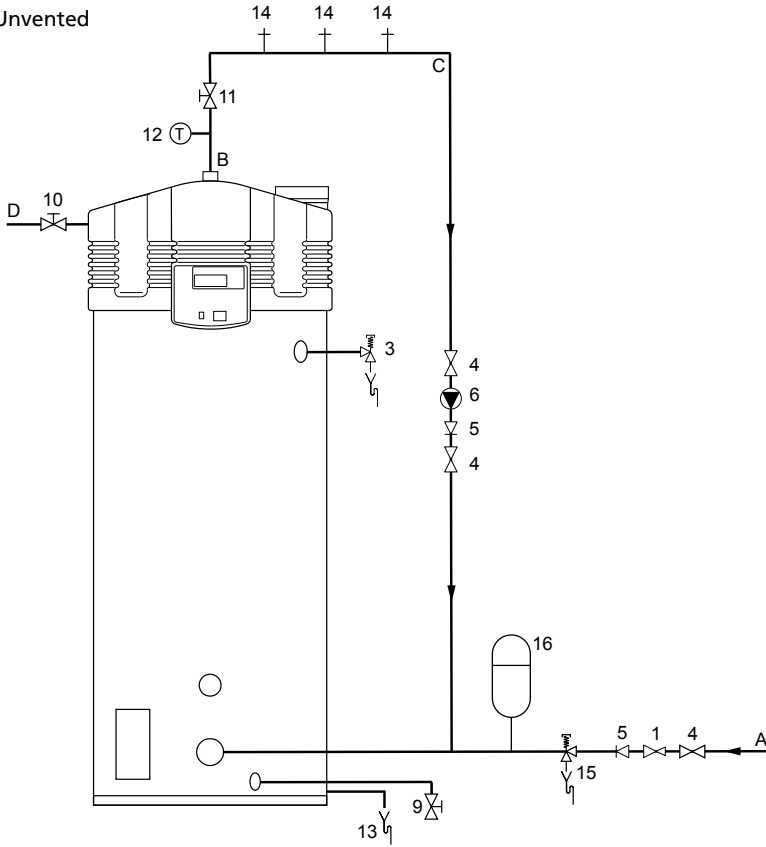

- 1 Pressure reducing valve
- 3 T&P valve
- 4 Stop valve
- 5 Non-return valve
- 6 Circulation pump
- 9 Drain valve
- 10 Gas valve
- 11 Service valve
- 12 Temperature meter
- 13 Condense drain
- 14 Hot water tap
- 15 Expansion valve
- 16 Expansion vessel
- 17 Three way valve
- 18 Water cistern
- 19 Float valve

- A Cold water supply
- B Hot water outlet
- C Circulation pipe
- D Gas supply
- E Overflow pipe
- H Overflow protection

A.O. Smith unvented system kits utilise combination valves.

Further installation and connection details can be found in the Installation & Commissioning Manual.

Vented

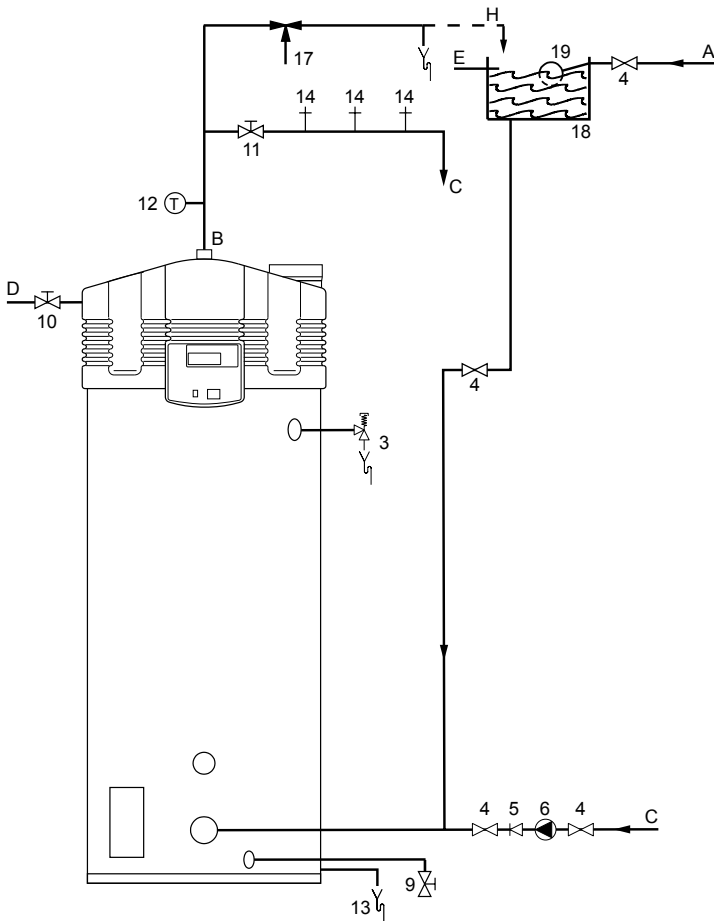

Installation options

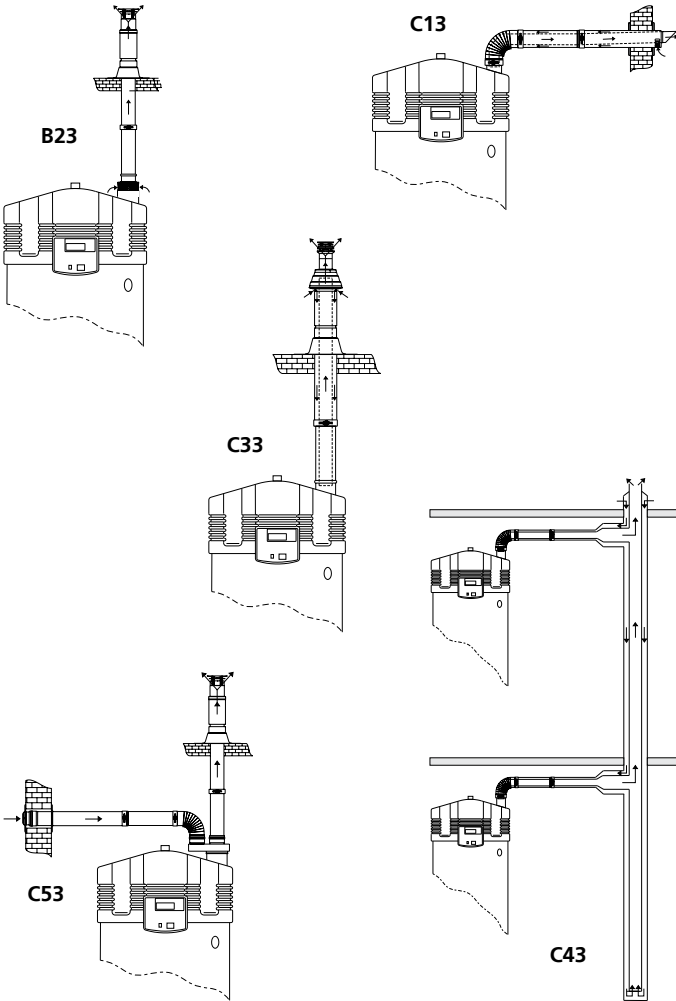

Further information on the flue gas discharge materials can be found in the Installation Manual.

A BFC Cyclone water heater should be installed according to category B23, C13, C33, C43 or C53*.

	BFC 28	BFC 30	BFC 50	BFC 60	BFC 80	BFC 100	BFC 120
Concentric							
Diameter (mm)	100/150	100/150	100/150	100/150	130/200	130/200	130/200
Max. length (m)	40	40	40	40	15	15	15
Max. 45/90° bends	7	7	7	7	4	4	4
Parallel (standard diameter)							
Diameter (mm)	100	100	100	100	130	130	130
Max. length (m)	55	55	55	55	65	65	65
Equivalent/bend 90° (m)	4.6	4.6	4.6	4.6	2.4	2.4	2.4
Equivalent/bend 45° (m)	1.2	1.2	1.2	1.2	1.4	1.4	1.4
Parallel (larger diameter for more length)							
Diameter (mm)	130	130	130	130	150	150	150
Max. length (m)	100	100	100	100	100	100	100
Equivalent/bend 90° (m)	2.4	2.4	2.4	2.4	2.6	2.6	2.6
Equivalent/bend 45° (m)	1.4	1.4	1.4	1.4	1.6	1.6	1.6
* All BFC Cyclone are also approved for installations where the unit is supplied without venting materials (C63).							
Concentric flues							
It is not permitted to use more than the specified number of bends, even when the duct is shorter than the maximum length. A 45° bend is equivalent to a 90° bend.							
Parallel flues							
- The maximum permissible length should be reduced by the equivalent length of each bend. (Note: for a parallel installation this means that 3 changes in direction amount to 6 bends (3 in the supply duct and 3 in the flue).)							
- The maximum length also applies if a parallel installation has different supply and flue duct lengths (B23, C53).							
- Combined flues (C43) shall be fitted with a condensate drain.							
Note: horizontal flue runs must be installed with a fall of at least 5 mm per metre.							

Minimum space requirements

BFC 28-60

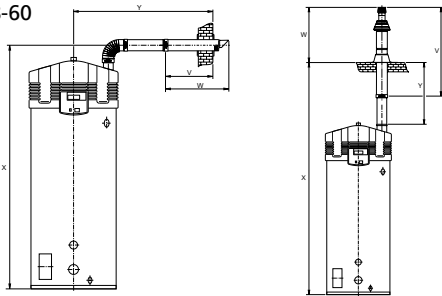

BFC 80-120

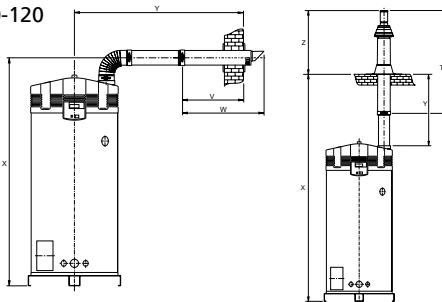

	BFC 28 Ø100/150	BFC 30 Ø100/150	BFC 50 Ø100/150	BFC 60 Ø100/150	BFC 80 Ø130/200	BFC 100 Ø130/200	BFC 120 Ø130/200
Minimal space for wall duct (mm)							
V	550	550	550	550	640	640	640
W	790	790	790	790	940	940	940
X	1535	2075	2075	2075	2230	2230	2230
X *	1985	2525	2525	2525	2680	2680	2680
Y	1480	1480	1480	1480	1620	1620	1620
Y *	1030	1030	1030	1030	1170	1170	1170
Minimal space for roof duct (mm)							
V	1500	1500	1500	1500	1730	1730	1730
W	1035	1035	1035	1035	1120	1120	1120
X	2965	3325	3325	3325	3620	3620	3620
X **	2015	2375	2375	2375	2670	2670	2670
Y	1415	1415	1415	1415	1560	1560	1560
Y **	465	465	465	465	610	610	610

* Distance without concentric pipe between bend and wall duct.
 ** Distance without concentric pipe between appliance and roof duct.

Data subject to change
 Terms and conditions apply, please refer to our